

## Model MY17HD0-1 Hybrid Stepper Motor

- High Torque
- Low Noise
- Unipolar or Bipolar Modes



### General Specifications

Step Accuracy: Maximum angular deviation is  $\pm 5\%$  of one step  
 Radial Play: Maximum 0.02mm at 450g  
 End Play: Maximum 0.08mm at 450g  
 Insulation Resistance: Minimum 100M $\Omega$  at 500V dc  
 Insulation Class: B  
 Temperature Rise: Maximum 80°C

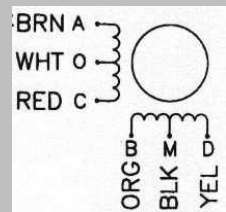

Model	Step Angle	Holding Torque (Unipolar)	No. of Leads	Phase Current	Phase Resistance	Phase Inductance	Rotor Inertia	Detent Torque	Mass	Body Length (L)
	Degree									
MY17HD0-1	1.8	90	6	0.16	75.0	60	28	15	210	34

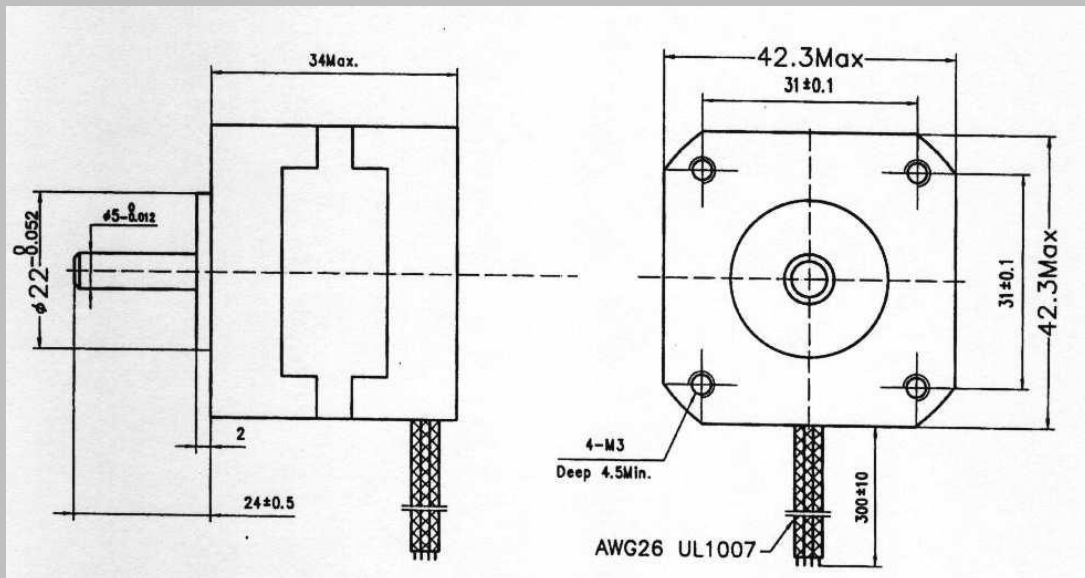

Dimensions (mm)