

Model MY14HY4-1 Hybrid Stepper Motor

- Low Inertia
- Small Size
- High Acceleration
- Light Weight
- Bipolar Mode

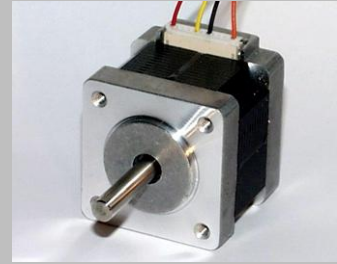

General Specifications

Step Accuracy:	Maximum angular deviation is $\pm 5\%$ of one step
Radial Play:	Maximum 0.02mm at 450g
End Play:	Maximum 0.08mm at 450g
Insulation Resistance:	Minimum 100M Ω at 500V dc
Insulation Class:	B
Temperature Rise:	Maximum 80°C

Wiring Diagram

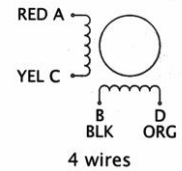

Model	Step Angle	Holding Torque (Bipolar)	No. of Leads	Phase Current	Phase Resistance	Phase Inductance	Rotor Inertia	Detent Torque	Mass	Body Length (L)
	Degree	mNm		A	Ω	mH	g.cm ²	mNm	g	mm
MY14HY4-1	1.8	110	4	0.75	5.7	7.0	14	12	180	34

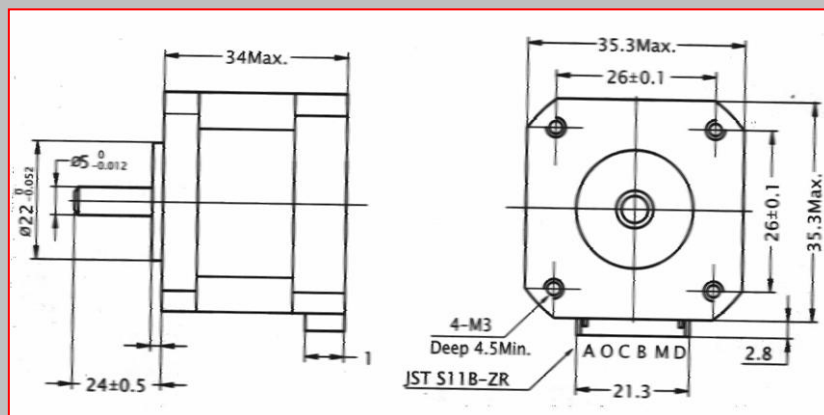

Dimensions (mm)